



REMEMBER:

Before installing or adjusting your sights, unload and/or check to ensure the firearm is unloaded.
WARNING: Use of a sight press for installation is not recommended as it can cause damage to sights/slide.

Dovetail Front Sight

Needed Tools: non-marring punch (brass, delrin, or nylon), Q-tips, fine file or emery paper, vise, alcohol

1. Place the slide in a padded vise.
2. Drive out the existing sight using a brass or steel punch.
3. Clean the factory dovetail until smooth (Q-tip, toothbrush, file as necessary).
4. Slide the sight into the dovetail. Entry side does not matter; test both sides to find the best fit. If it goes in at least half way, or loosely slides through, skip to 7. **Friction fit is not necessary.**
5. Using a fine file or emery paper on a flat surface, remove steel from the bottom of the Express Sight until it will enter the dovetail halfway. (See Figure 1) Do not file the dovetail (A) shorter than the depth (B) noted in Figure 2. If the sight still does not fit, but you have reached the minimum height, move to step 6; otherwise, skip to step 7.

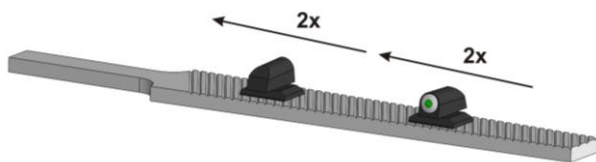
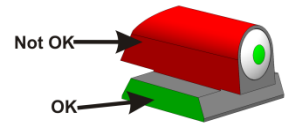

Figure 1

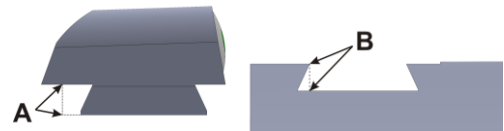
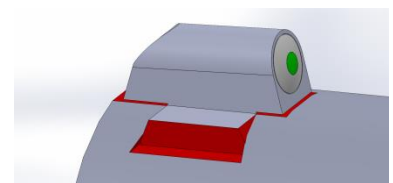

Figure 2

6. Using an angled dovetail file, file on the angled faces of the dovetailed portion of the sight until the sight enters halfway. (file info should be a footnote)
 - a. 65° 1911 Dovetail Type Slot Straight Base file 080-648-265WB
 - b. 60° Dovetail Slot sight base file 080-648-260WB
7. Remove the sight. Degrease the slot and the sight.
8. Apply red threadlocking compound to all mating surfaces.
**Red threadlocker is a necessary component of our sight installation process - sights can fall off without the use of red threadlocker.*
9. Install the sight using a non-marring punch.
10. Let sit for 10 minutes, and then lightly remove the excess clumps of red threadlocking compound with a Q-tip. In this initial clean-up, do not clean aggressively, as you will remove the compound from the joint. Let it set for 3 hours.
11. Wipe sights down with protective oil in a light coating to prevent potential rust issues.





REAR SIGHT

1. Place the slide in a padded vise.
2. Drive out the existing sight using a brass or steel punch. Berettas exit to the left only.
3. Clean the factory dovetail until smooth (Q-tip, toothbrush, file as necessary).
4. Slide the sight into the dovetail. If it goes at least halfway, or fits without resistance, skip to step 6. **Friction fit is not necessary.**
5. Using a fine file or emery paper, remove steel from the bottom of the sight until it will enter the dovetail halfway.

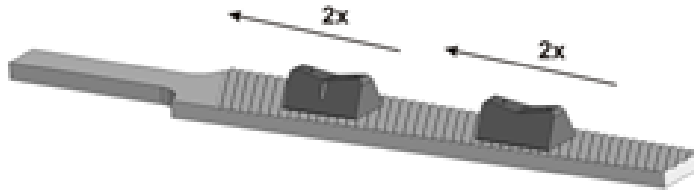

6. Remove the sight. Degrease the dovetail and the sight.
7. Install the sight and snug down the set screws using finger pressure only. If you wish to zero the sights at this time you may, note the adjustment of the rear sight. Under recoil, set screws will loosen after several shots.
8. When you are satisfied with your zero, apply red threadlocking compound to both the right and left edges of the sight and allow it to leach under the sight. This will lock the sight in place but still allow for windage adjustments with the non-marring punch by drifting the sight left and right. **Red threadlocker is a necessary component of our installation process – sights will fall off without the use of red threadlocker.*

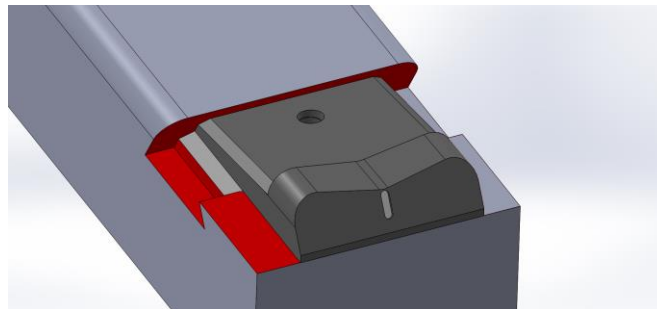

9. Let the slide sit for 10 minutes, then lightly remove the excess clumps of red threadlocking compound with a Q-tip. In this initial clean-up, do not clean aggressively, as you will remove the compound from the joint. Let it set for 3 hours.
10. Wipe sights down with protective oil in a light coating to prevent potential rust issues.